

Engineered Sound®

[Description]

The ES945 is a wide-range condenser microphone with an omnidirectional polar pattern. It is designed for unobtrusive table, ceiling or panel-mounted applications for high-quality sound reinforcement, teleconferencing, professional recording, television and other demanding sound pickup applications.

The ES947 is a similar microphone with a unidirectional polar pattern. Positioning a properly designed miniature unidirectional microphone centrally on a large, flat, unobstructed surface yields several distinct advantages. The directivity factor is greatly increased over a comparable omnidirectional microphone, thus promoting enhanced gain before feedback and further suppressing

ambient noise. Sensitivity is increased for improved signal-to-noise ratio. Phase distortion due to reflected sound energy from the boundary itself is eliminated.

Both microphones require 9V to 52V DC phantom power for operation. The microphones are enclosed in a heavy-duty die-cast case and protected by two layers of heavy perforated steel. The low-profile housing has a low-reflectance black finish. The microphones are also available in white as the ES945W and ES947W. Isolators are included with each microphone for optional mechanical isolation from the mounting surface.

ES945 Omnidirectional Condenser Boundary Microphone



[Installation and Operation]

Output is low impedance balanced. The balanced signal appears across Pins 2 and 3, while the ground (shield) connection is Pin 1. Output is phased so that positive acoustic pressure produces positive voltage at Pin 2 in accordance with industry convention.

To mount these microphones in a ceiling or table top *without* the isolators, a $\frac{13}{16}$ " (20.5 mm) diameter hole is required. To mount these microphones *with* the isolators, a $\frac{15}{16}$ " (23.5 mm) hole is required. The isolators can be placed on either side of the hole for mechanical isolation from the mounting surface.

The Audio-Technica emblem () on the ES947 bezel indicates the "front" of the microphone.

While a modern fixed-charge condenser microphone is not unduly sensitive to the environment, temperature extremes can be harmful. Exposure to high temperature can result in gradual and permanent reduction of the output level. Avoid leaving the microphone in the open sun or in areas where temperatures exceed 110° F (43° C) for long periods of time. Extremely high humidity should also be avoided.

ES947 Cardioid Condenser Boundary Microphone



[Architects and Engineers Specifications]

ES945 [ES945W]

The microphone shall be a fixed-charge condenser designed for use in table, ceiling or panel-mount boundary applications. It shall have a frequency response of 30 Hz to 20,000 Hz and an omnidirectional polar pattern. It shall have a self-contained power module and shall operate from an external 9V to 52V DC phantom power source. It shall be capable of handling sound input levels up to 142 dB with a dynamic range of 112 dB. Nominal open-circuit output voltage shall be 7.9 mV at 1 kHz, 1 Pascal. Output shall be low impedance balanced (200 ohms) from an integral 3-pin XLRM-type connector.

The microphone shall have a maximum diameter of 1.10" (28.0 mm) and an overall length of 2.72" (69.0 mm). Weight shall be 2.1 oz (60 grams). The microphone shall be housed in an all-metal case with a two-layer steel mesh grille. Finish shall be low-reflectance black [white]. Resilient isolators shall be provided for reduction of mechanical noise transfer from the mounting panel.

The Audio-Technica ES945 [ES945W] is specified.

ES947 [ES947W]

The microphone shall be a fixed-charge condenser designed for use in table, ceiling or panel-mount boundary applications. It shall have a frequency response of 30 Hz to 20,000 Hz and a unidirectional polar pattern. It shall have a self-contained power module and shall operate from an external 9V to 52V DC phantom power source. It shall be capable of handling sound input levels up to 142 dB with a dynamic range of 113 dB. Nominal open-circuit output voltage shall be 7.9 mV at 1 kHz, 1 Pascal. Output shall be low impedance balanced (200 ohms) from an integral 3-pin XLRM-type connector.

The microphone shall have a maximum diameter of 1.18" (30.0 mm) and an overall length of 2.72" (69.0 mm). Weight shall be 2.2 oz (62 grams). The microphone shall be housed in an all-metal case with a two-layer steel mesh grille. Finish shall be low-reflectance black [white]. Resilient isolators shall be provided for reduction of mechanical noise transfer from the mounting panel.

The Audio-Technica ES947 [ES947W] is specified.



audio-technica®

[ES945, ES947 Specifications†]

Element	Fixed-charge back plate permanently polarized condenser
Polar Pattern	
ES945	Omnidirectional
ES947	Unidirectional (Cardioid in hemisphere above mounting surface)
Frequency Response	30-20,000 Hz
Open Circuit Sensitivity	-42 dB (7.9 mV) re 1V at 1 Pa*
Impedance	200 ohms
Maximum Input Sound Level	142 dB SPL, 1 kHz at 1% T.H.D.
Dynamic Range (Typical)	
ES945	112 dB, 1 kHz at Max SPL
ES947	113 dB, 1 kHz at Max SPL

Signal-to-noise Ratio¹	
ES945	64 dB, 1 kHz at 1 Pa*
ES947	65 dB, 1 kHz at 1 Pa*
Phantom Power Requirements	9-52V DC, 2 mA typical
Weight	
ES945	2.1 oz (60 grams)
ES947	2.2 oz (62 grams)
Dimensions	
ES945	1.10" (28.0 mm) dia., 2.72" (69.0 mm) length
ES947	1.18" (30.0 mm) dia., 2.72" (69.0 mm) length
Output Connector	Integral 3-pin XLRM-type
Accessory Furnished	One pair isolators

† In the interest of standards development, A.T.U.S. offers full details on its test methods to other industry professionals on request.

* 1 Pascal = 10 dynes/cm² = 10 microbars = 94 dB SPL

¹ Typical, A-weighted, using Audio Precision System One.

Specifications subject to change without notice.

[Polar Pattern]

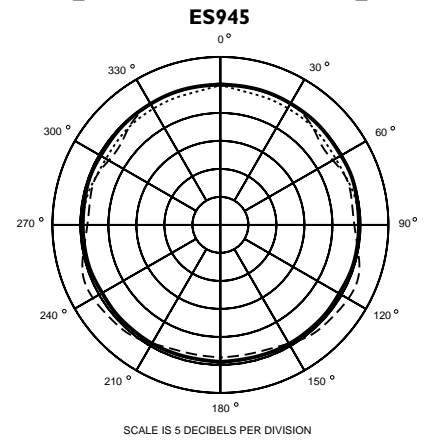

LEGEND
 1 kHz ———
 5 kHz - - - - -
 8 kHz ······

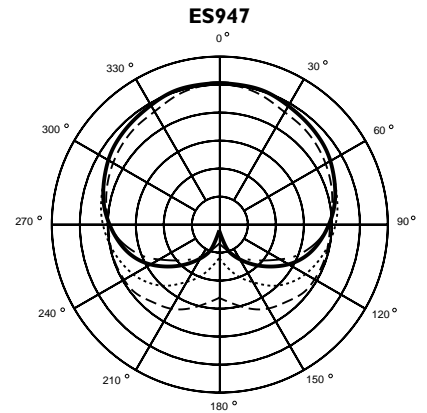

LEGEND
 100 Hz ———
 1 kHz - - - - -
 5 kHz ······
 8 kHz - - - - -

[Dimensions]

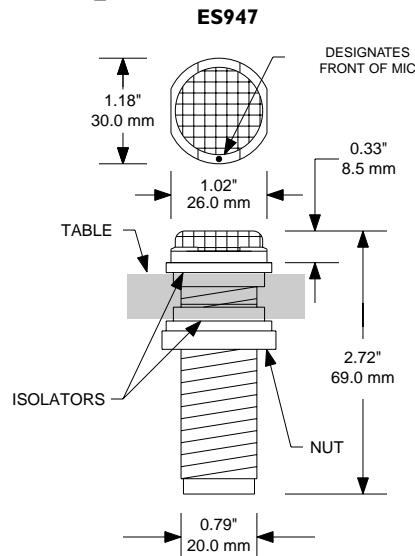
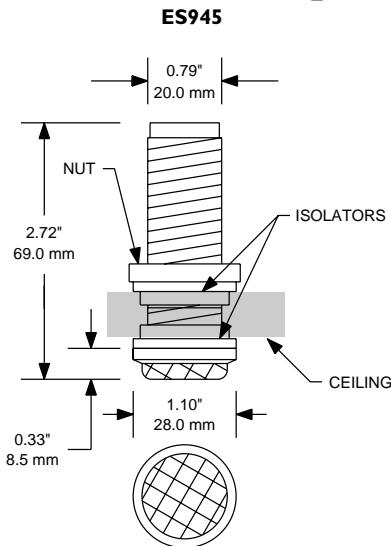

[Frequency Response]

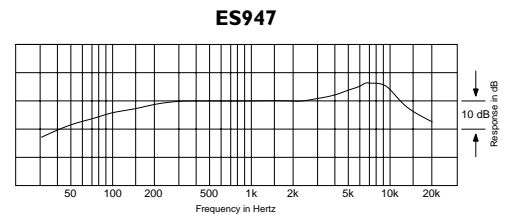
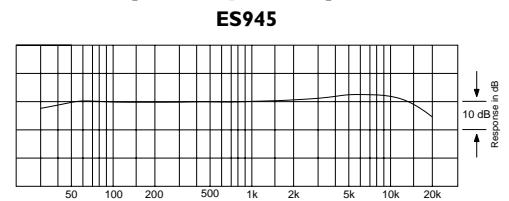

LEGEND ——— 12" or more on axis

[Visit our Web site at www.audio-technica.com]

One-Year Limited Warranty

Audio-Technica microphones and accessories purchased in the U.S.A. are warranted for one year from date of purchase by Audio-Technica U.S., Inc. (A.T.U.S.) to be free of defects in materials and workmanship. In event of such defect, product will be repaired promptly without charge or, at our option, replaced with a new product of equal or superior value if delivered to A.T.U.S. or an Authorized Service Center, prepaid, together with the sales slip or other proof of purchase date. **Prior approval from A.T.U.S. is required for return.** This warranty excludes defects due to normal wear, abuse, shipping damage, or failure to use product in accordance with instructions. This warranty is void in the event of unauthorized repair or modification.

For return approval and shipping information, contact the Service Department, Audio-Technica U.S., Inc., 1221 Commerce Drive, Stow, Ohio 44224.

Except to the extent precluded by applicable state law, **A.T.U.S. will have no liability for any consequential, incidental, or special damages; any warranty of merchantability or fitness for particular purpose expires when this warranty expires.**

This warranty gives you specific legal rights, and you may have other rights which vary from state to state.

Outside the U.S.A., please contact your local dealer for warranty details.



audio-technica®

Audio-Technica U.S., Inc.
 1221 Commerce Drive, Stow, Ohio 44224
Audio-Technica Limited
 Old Lane, Leeds LS11 8AG England